

Technical data sheet

Product features



Convection oven STEAMBOX electric 20x GN 1/1 boiler Color touch screen Automatic cleaning 10" display

Model	SAP Code	00038577
STMB 2011 E	A group of articles - web	Convection machines



- Number of GN / EN: 20
- GN / EN size in device: GN 1/1
- GN device depth: 65
- Control type: Touchscreen
- Display size: 10"
- Humidity control: MeteoSystem - regulation based on direct measurement of humidity in the chamber (patented)
- Advanced moisture adjustment: Steamtuner - 5-stage system of setting steam saturation by controlled combination of production by boiler or injection
- Delta T heat preparation: Yes
- Automatic preheating: Yes
- Multi level cooking: Drawer program - control of heat treatment for each dish separately
- Door constitution: Odvětrávané bezpečnostní trojitě sklo, rozebíratelné pro snadné čištění

SAP Code	00038577	Loading	400 V / 3N - 50 Hz
Net Width [mm]	995	Number of GN / EN	20
Net Depth [mm]	835	GN / EN size in device	GN 1/1
Net Height [mm]	1850	GN device depth	65
Net Weight [kg]	260.00	Control type	Touchscreen
Power electric [kW]	33.300	Display size	10"

Technical data sheet

Technical drawing



Convection oven STEAMBOX electric 20x GN 1/1 boiler Color touch screen Automatic cleaning 10" display

Model	SAP Code	00038577
STMB 2011 E	A group of articles - web	Convection machines

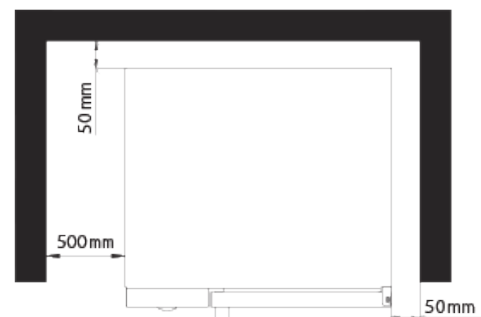
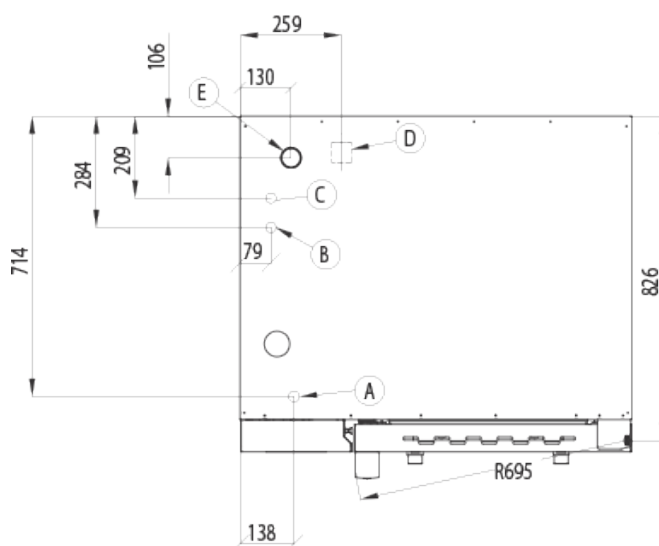
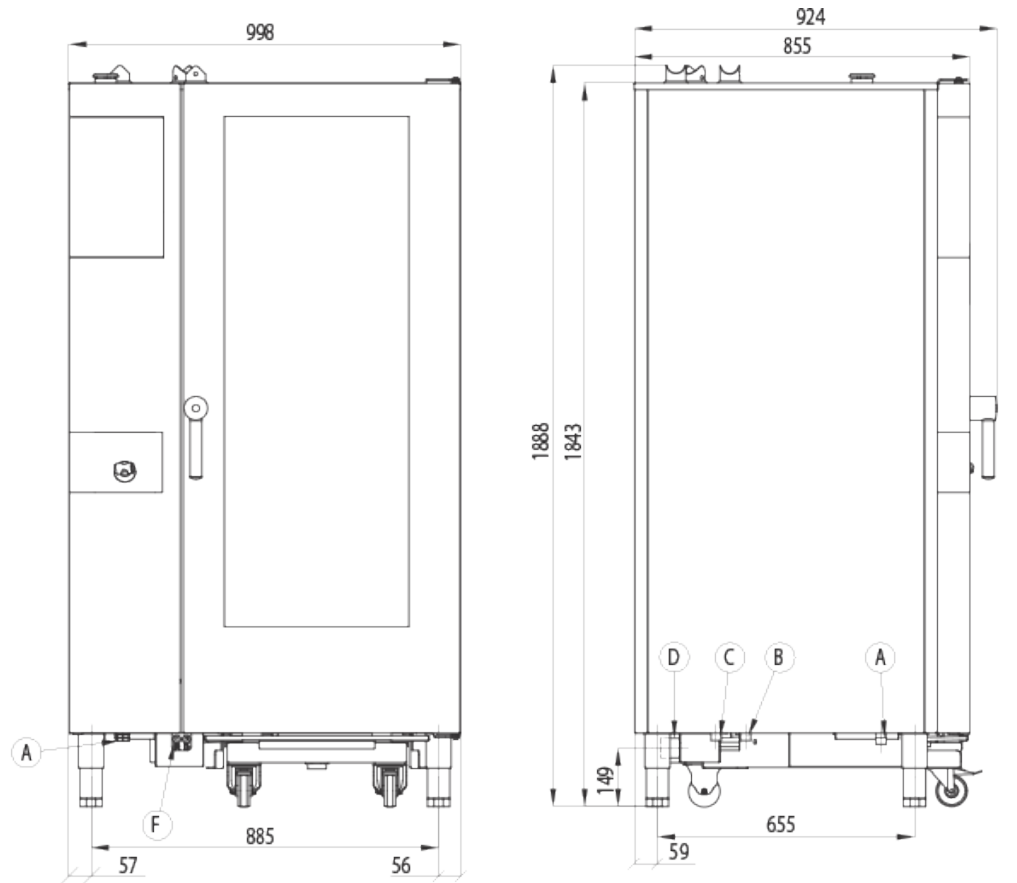

* Clearance requirements

NOTE

* Drain line must be vented

Technical data sheet

Product benefits



Convection oven STEAMBOX electric 20x GN 1/1 boiler Color touch screen Automatic cleaning 10" display

Model	SAP Code	00038577
STMB 2011 E	A group of articles - web	Convection machines

1

Triple glass door as standard

better thermal insulation, less frequent reheating, safer operation due to lower outer glass temperature, less radiant heat, less heat leakage, lower load on electronics and mechanical parts

- reduction of heat losses, saving operating costs, reduced risk of injury to the operator when touching the glass, more pleasant working temperature in the kitchen, welcomed especially in the hot summer months, saving operating, service and acquisition costs thanks to the fact that the equipment suffers less from temperature fluctuations and wear

2

Clear 10" touch screen corresponding to other RM line devices

simple intuitive operation using images and visualizations, the same intuitive operation as on other digital devices in the RM line

- saving time when entering programs or cooking itself, saving time when training personnel, when operating the RM line equipment itself, saving costs and time

3

Smart cooking

Predefined basic programs for easy control with just a few touches

- saving human qualifications, time when creating programs

4

Symbiotic steam generation system

simultaneous use of "direct injection" and boiler, maintaining 100% humidity, or its regulation

- preparation of various dishes and cooking styles in an environment precisely set for a given food or dish

5

Self-winding shower

drum reel integrated in the combi oven body the shower is inaccessible after closing the door

- enables pouring food in the convection oven and rinsing the chamber - or speeds up the cooling of the chamber

6

Fan six-speed, reversible with automatic calculation of direction change

in cooperation with the symbiotic system, it ensures perfect distribution of steam without loss of its saturation, its operation is controlled by program or manually

- enables the preparation of various dishes from the most delicate to baking at high temperatures at the highest speeds

7

External temperature probe

temperature probe placed outside the cooking space option to choose from a single or multi-point probe or vacuum probe

- placing it outside the cooking chamber extends its service life
- ensuring complete hygienic safety of dishes
- HACCP recording
- control of heat treatment in the absence chef

8

Longitudinal drawers for GN

drawers placed at the "depth" of the machine option to replace with drawers for 600x400 trays

- possibility to insert the entire GN range, not just the 1/1 size, possibility to use 600x300 baking trays

9

USB

downloading service reports
upgrade software
playback recipes

- quick fault finding
- transfer of original recipes
- maintaining up-to-date software

10

Automatic washing

integrated chamber washing system
option to use liquid and tablet detergents
option to use vinegar as a rinse aid
the system also descales the micro-boiler

- the combi steamer chamber is washed without the presence of the operator, for example overnight
- the system descales the micro-boiler without the need for service intervention
- the chamber is maintained in constant 100% hygienic quality

Technical data sheet

Technical parameters



Convection oven STEAMBOX electric 20x GN 1/1 boiler Color touch screen Automatic cleaning 10" display

Model	SAP Code	00038577
STMB 2011 E	A group of articles - web	Convection machines

1. SAP Code:

00038577

2. Net Width [mm]:

995

3. Net Depth [mm]:

835

4. Net Height [mm]:

1850

5. Net Weight [kg]:

260.00

6. Gross Width [mm]:

1150

7. Gross depth [mm]:

1050

8. Gross Height [mm]:

2100

9. Gross Weight [kg]:

290.00

10. Device type:

Electric unit

11. Power electric [kW]:

33.300

12. Loading:

400 V / 3N - 50 Hz

13. Material:

AISI 304

14. Exterior color of the device:

Stainless steel

15. Adjustable feet:

Yes

16. Humidity control:

MeteoSystem - regulation based on direct measurement of humidity in the chamber (patented)

17. Stacking availability:

Yes

18. Control type:

Touchscreen

19. Additional information:

possibility of reverse door opening - handle on the right side (must be specified when ordering)

20. Chimney for moisture extraction:

Yes

21. Delayed start:

Yes

22. Display size:

10"

23. Delta T heat preparation:

Yes

24. Automatic preheating:

Yes

25. Automatic cooling:

Yes

26. Cold smoke-dry function:

Yes

Technical data sheet

Technical parameters



Convection oven STEAMBOX electric 20x GN 1/1 boiler Color touch screen Automatic cleaning 10" display

Model	SAP Code	00038577
STMB 2011 E	A group of articles - web	Convection machines

27. Unified finishing of meals EasyService:

Yes

28. Night cooking:

Yes

29. Washing system:

Closed - efficient use of water and washing chemicals by repeated pumping

30. Detergent type:

Liquid washing detergent + liquid rinse aid/vinegar or washing tablets

31. Multi level cooking:

Drawer program - control of heat treatment for each dish separately

32. Advanced moisture adjustment:

Steamtuner - 5-stage system of setting steam saturation by controlled combination of production by boiler or injection

33. Slow cooking:

from 30 °C - the possibility of rising

34. Fan stop:

Immediate when the door is opened

35. Lighting type:

LED lighting in the doors, on both sides

36. Cavity material and shape:

AISI 304, with rounded corners for easy cleaning

37. Reversible fan:

Yes

38. Sustance box:

Yes

39. Heating element material:

Incoloy

40. Probe:

Yes

41. Shower:

Hand winder

42. Smoke-dry function:

Yes

43. Interior lighting:

Yes

44. Low temperature heat treatment:

Yes

45. Number of fans:

2

46. Number of fan speeds:

6

47. Number of programs:

1000

48. USB port:

Yes, for uploading recipes and updating firmware

49. Door constitution:

Odvětrávané bezpečnostní trojitě sklo, rozebíratelné pro snadné čištění

50. Number of preset programs:

100

Technical data sheet

Technical parameters



Convection oven STEAMBOX electric 20x GN 1/1 boiler Color touch screen Automatic cleaning 10" display

Model	SAP Code	00038577
STMB 2011 E	A group of articles - web	Convection machines

51. Number of recipe steps:

9

52. Minimum device temperature [°C]:

30

53. Maximum device temperature [°C]:

300

54. Device heating type:

Combination of steam and hot air

55. HACCP:

Yes

56. Number of GN / EN:

20

57. GN / EN size in device:

GN 1/1

58. GN device depth:

65

59. Food regeneration:

Yes

60. Cross-section of conductors CU [mm²]:

10

61. Diameter nominal:

DN 50

62. Water supply connection:

3/4"